

TECHNICAL SPECIFICATIONS

General Specifications:

Power supply	12 Vdc (10 V - 15 V)
Alarm control unit consumption	Disabled < 2.5 mA - Enabled < 5.5 mA
Operating temperature	-40°C +85°C
Immunity time	26 sec.
Indicator flashing during alarm	0.4 sec. ON; 0.4 sec. OFF
Alarm cycle time	26 sec.
Alarm cycles for different triggers	95/56/EC (European standards)

Protection:

Volumetric protection	Ultrasonic Echo/Doppler system, disabled by radio remote control.
Tilt/shock sensor protection	Tilt or shock sensor, selected via PRG007
Panic Alarm	Pressing the radio remote control produces an alarm.
Perimeter Protection	3 independent inputs for protecting the doors, boot and bonnet
Alarm input from auxiliary modules	Positive input, disabled by radio remote control
Output to drive Engine Immobilizer Relay	Negative electronic control, 1 A max
Protection against attempted ignition	Produces an acoustic alarm when the alarm is enabled
Automatic anti-theft protection	Protection enabled via PRG007 programmer

Controls and services:

Alarm Enable/Disable	Using supplied radio remote control (433.92 MHz)
Central locking	6-wire universal, with times selected via PRG007
Direction indicator control output	Positive electronic control, 5 A + 5 A max
Blinker button drive output	Negative electronic control, 1 A max
Alarm output for Horn/Pager relay	Negative electronic control, 1 A max
Control output for electric window module	Delayed positive electronic control
Original electric window comfort control	Automatic or via radio remote control.
Safety deadlock control for central locking	Control enabled via PRG007 programmer
Emergency disable	Button/LED or electronic keys (4 max)
Beeper when enabling/disabling alarm	Signal enabled via PRG007 programmer
Door open warning when enabled	Signals if a door, boot or bonnet are open when enabling the alarm.
Flashing LED	Signal that displays the alarm and alarm memory status

Compatible sirens:

WFR radio siren	116 dB sound level, self-powered
M05 self-powered encoded siren	116 dB sound level, self-powered
M03 piezoelectric siren	114 dB sound level, not self-powered

DISCONNECT THE VEHICLE BATTERY

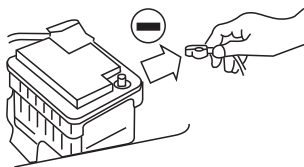

INSTALLING THE SIREN IN THE ENGINE COMPARTMENT

80°C



H₂O

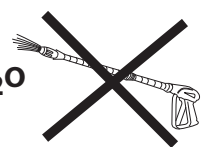

SETTING UP THE PRODUCT

- Use the PRG007 PROGRAMMER to select the various functions of the product.
- Software updates for the PRG007 programmer and information about the programmable functions are available ONLINE in the CAR-ALARM technical area of the www.metasystem.it website.

PRG007 PROGRAMMER MetaSystem code: ABS15090

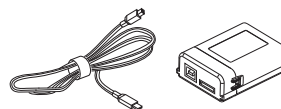

WIRING FOR Meta HPA MetaSystem code: ABS14090

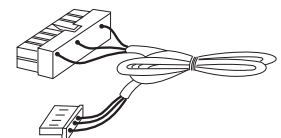

RADIO REMOTE CONTROLS

STANDARD RADIO RANGE

TX Mykro

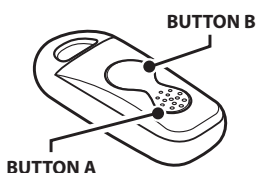

M252

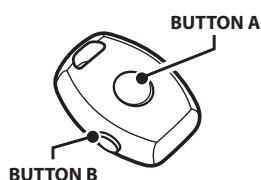

EXTENDED RADIO RANGE

M4502

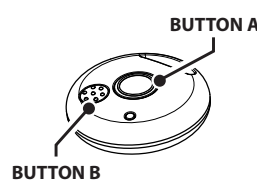

M4512

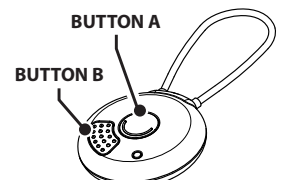

GENERAL DIAGRAM

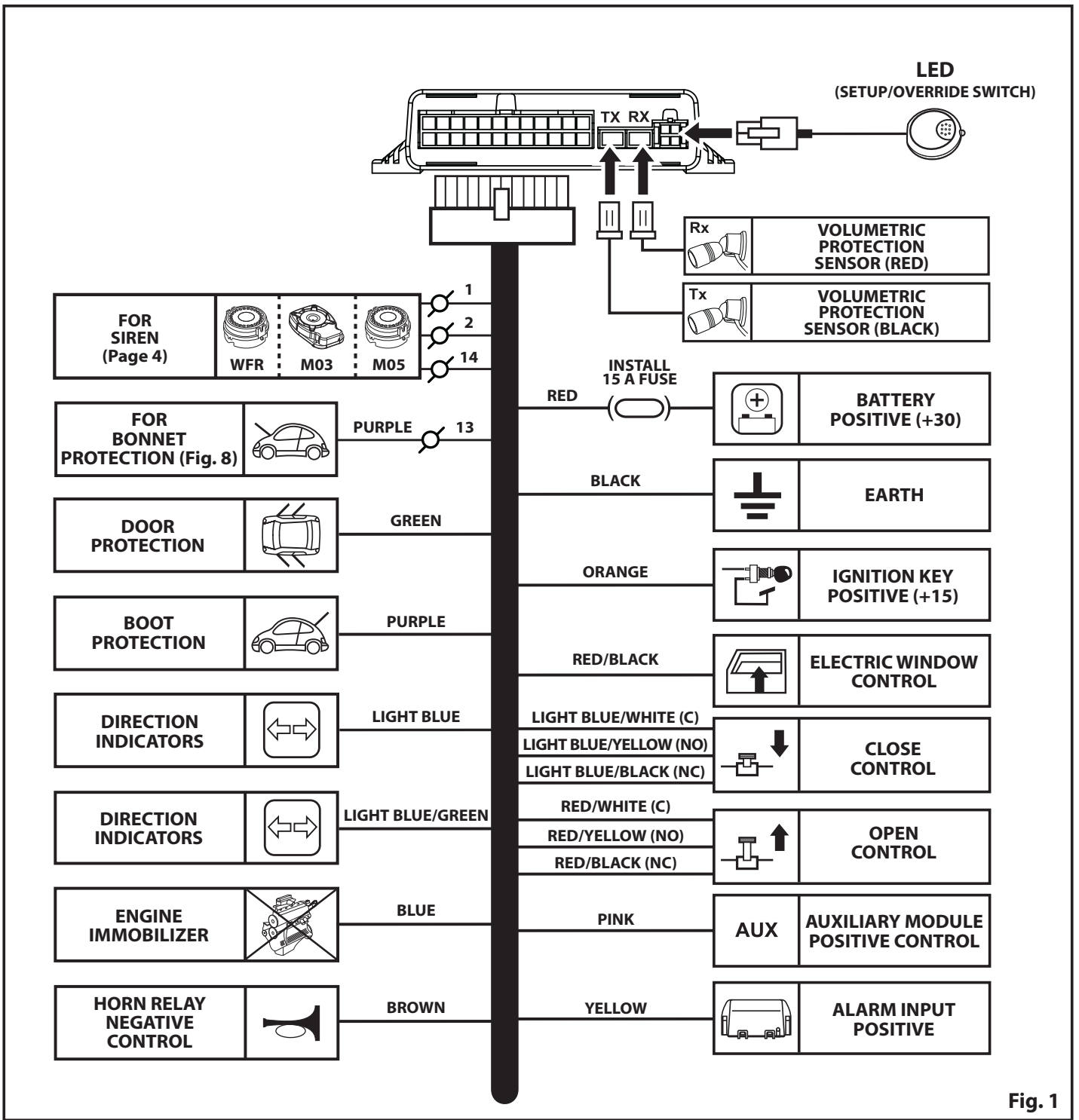
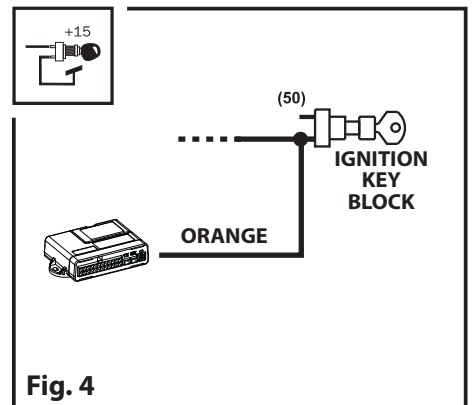
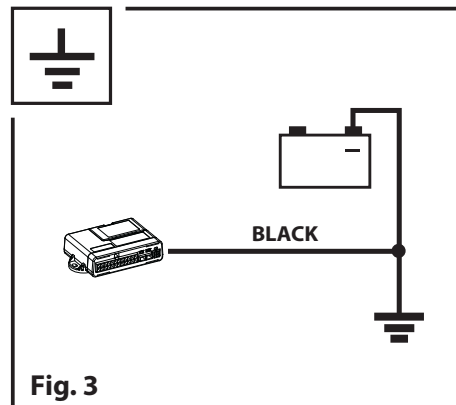
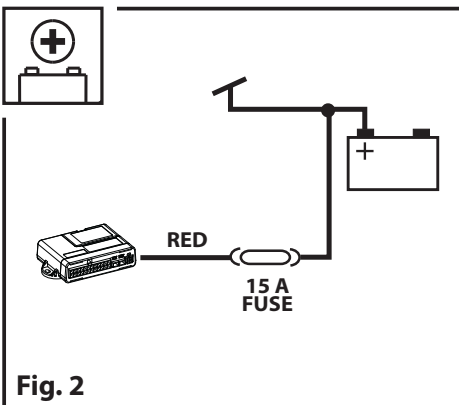

Fig. 1

MAIN POWER SUPPLY/IGNITION KEY POSITIVE



CONNECTING THE SIREN



The Meta HPA Evo control unit automatically recognizes the siren model and adapts to it. It is recognized by a BOOP emitted when the alarm system is powered up, so the installer must connect it before powering up the alarm system.

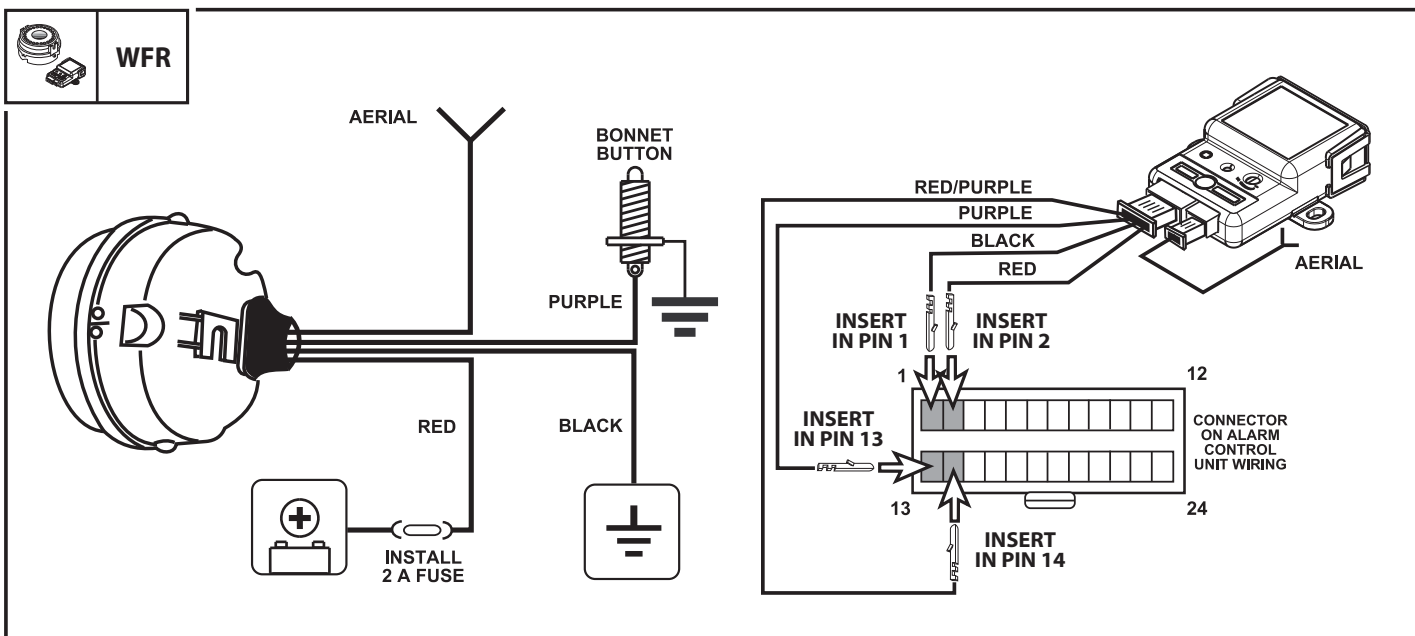
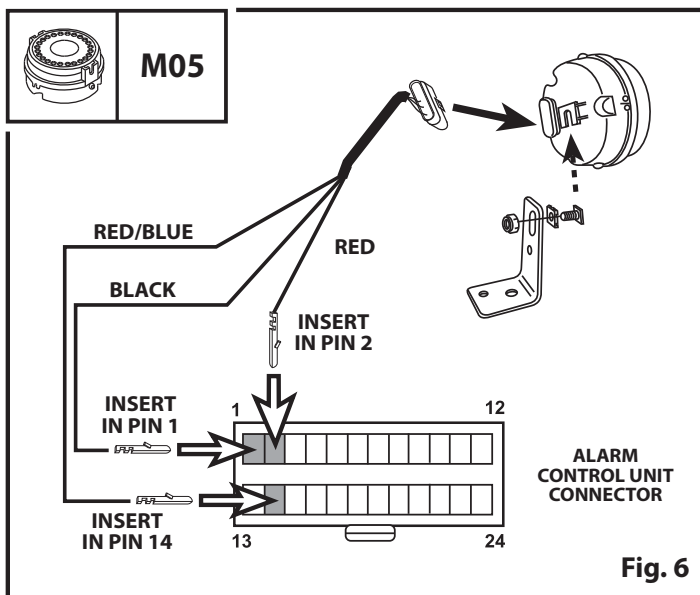
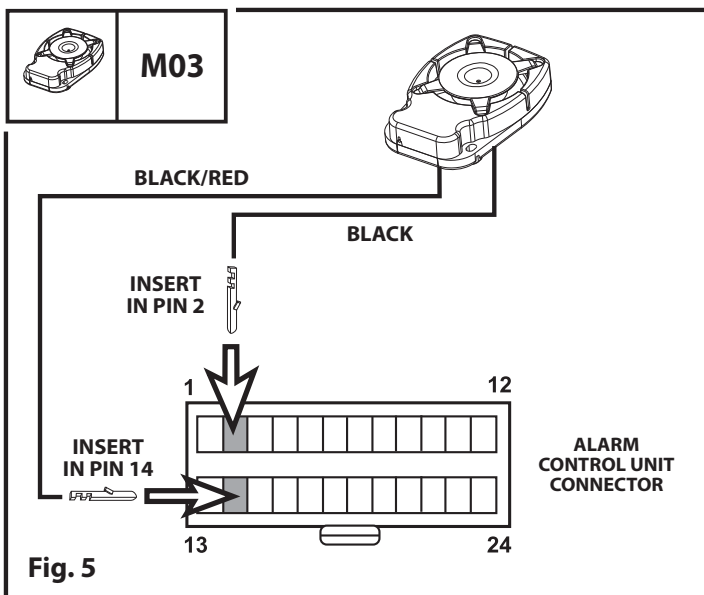

PAIRING THE SIREN WITH THE ALARM (SIREN SELF-LEARNING PROCEDURE)

Phase 1: disconnect the alarm control unit connector and insert the four pins from the module wiring. Plug the 2-way connector with the aerial lead into the module.



During phase 2, leave the alarm control unit connector **DISCONNECTED**.

Phase 2: power up the siren and, within 30 seconds, press the boot button connected to the siren 5 times, or if there is no boot button connected to the siren, give 5 GND pulses on the purple wire in the siren wiring. To confirm that your radio module has entered the learning phase, the siren will emit a Bip Boop Bip Boop acoustic signal, and remain in the learning phase for 3 minutes from this moment.

Phase 3: power up the alarm control unit within 3 minutes from when the siren is ready for pairing. To confirm that the pairing was successful, the siren will emit a Bip Beep Bip Beep acoustic signal.

Fig. 7



CAUTION! RISK OF EXPLOSION IF THE BATTERY IS REPLACED WITH THE INCORRECT TYPE.
ONLY USE THE CORRECT BATTERIES INDICATED IN THE INSTRUCTIONS.



PERIMETER PROTECTION

Only use the existent buttons if they close to earth.

DOORS

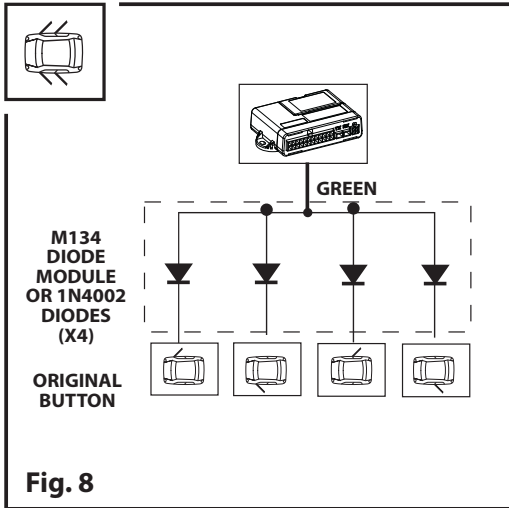

BONNET

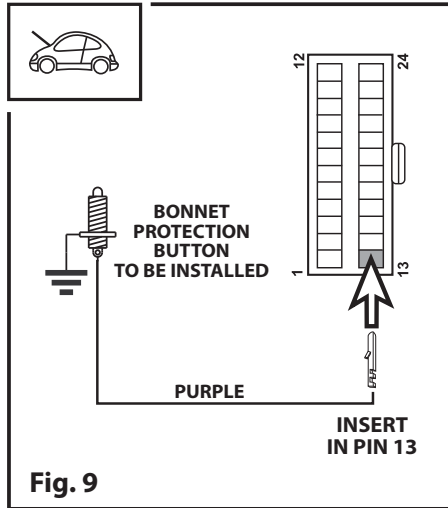

BOOT

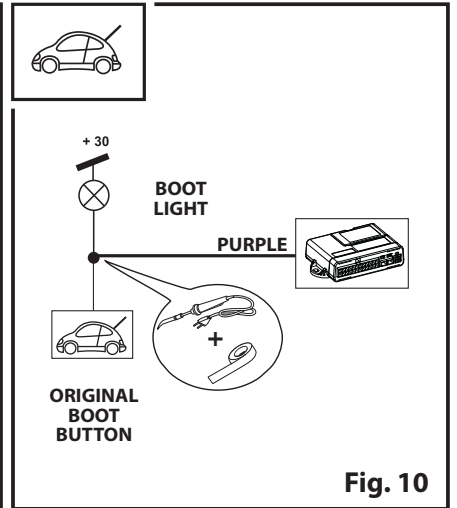

ALARM OUTPUT FOR HORN/TELEMATIC DEVICE RELAY

During an alarm cycle, there is negative control on the BROWN wire to drive either the original relay or an additional one for the vehicle horn or telematic device, as applicable. This negative control may be either direct or alternating, as selected on the PRG007 PROGRAMMER. Follow the indications in figures 11 and 12 for the various types of connection.

NEGATIVE CONTROL

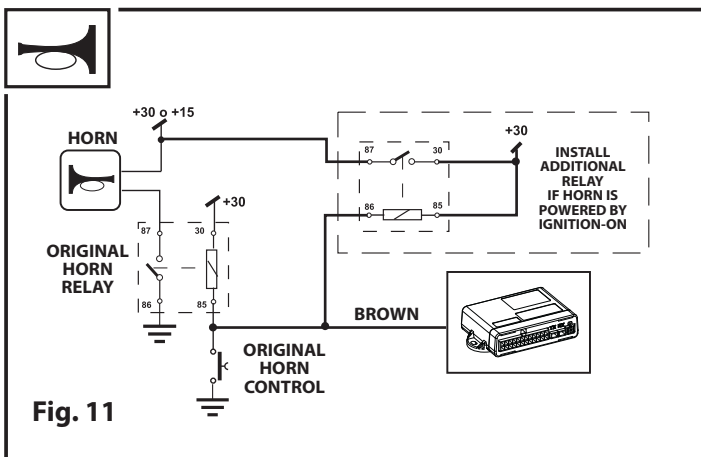

POSITIVE CONTROL

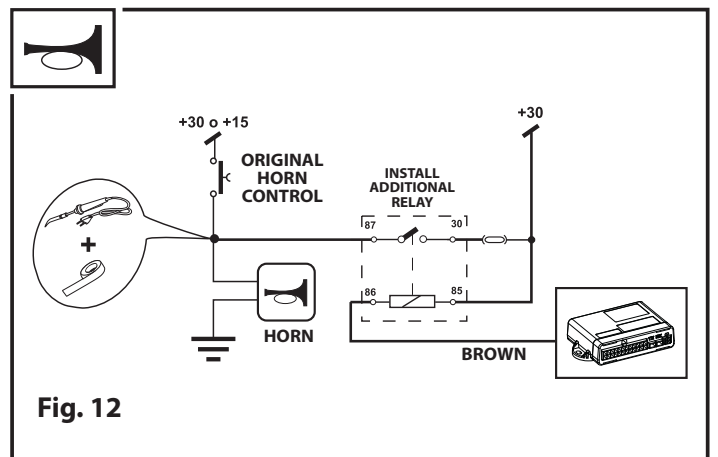

BLINKER DRIVE

This product drives the direction indicators with positive signals connected directly to the lamps (fig. 13) or with negative signals directly to the Hazard Warning Light button on the vehicle (fig. 14). It is also possible to extend the indicator lamp flashing time by 25 sec. when the alarm stops. Use the PRG007 programmer to select the desired drive type and extended flashing time.

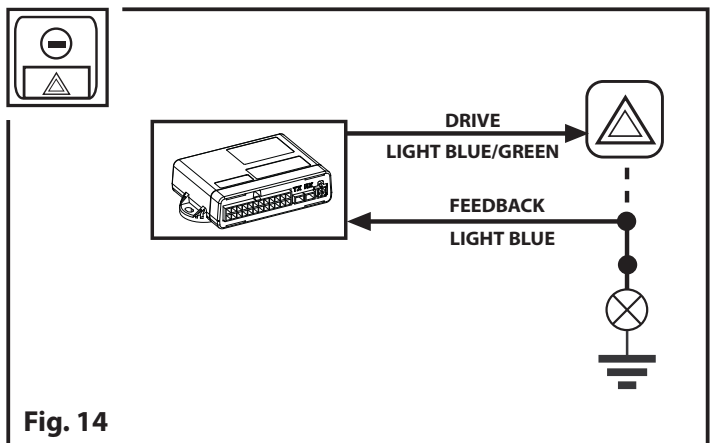
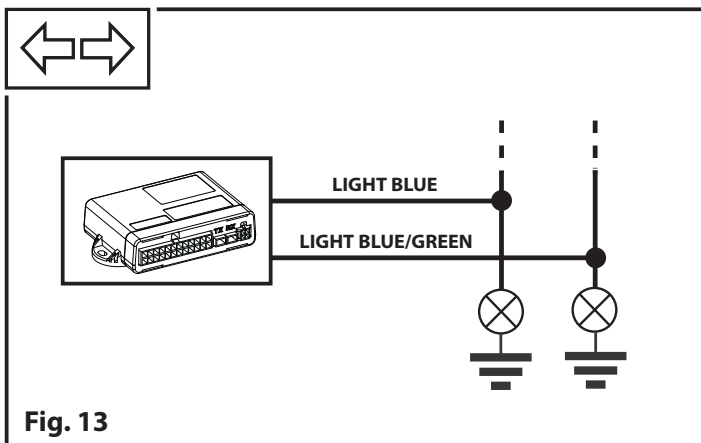

ENGINE IMMOBILIZER

An attempt to start the engine with the control unit enabled activates the internal relay, which opens the engine immobilizer circuit.

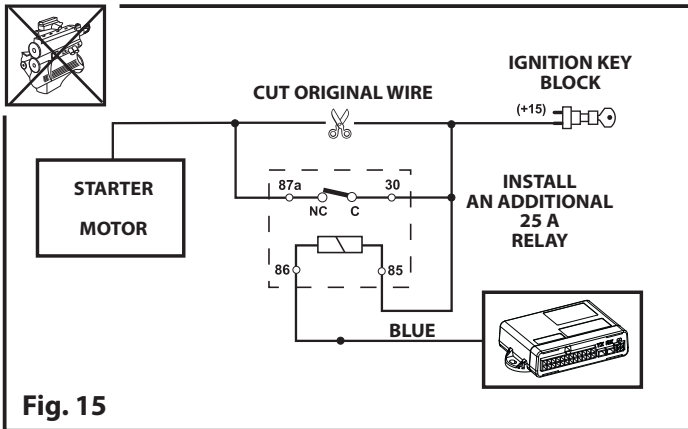

Fig. 15

ELECTRIC WINDOW MODULE AND WINDOW CLOSING DISABLE CONTROL

When the alarm is enabled, a POSITIVE control is given on the PINK/BLACK wire after a 12 sec. delay to drive the electric window accessory module.

If you want to enable the alarm without closing the windows, just press the button/LED button a short time after enabling the alarm with the radio remote control.

AUXILIARY PROTECTION MODULE

It is possible to use additional modules with the alarm, and to disable them temporarily as for the volumetric protection.

For this purpose, there is a positive output line dedicated to driving the modules (PINK wire) and an input for the alarm signal generated by them (YELLOW wire).

VOLUMETRIC PROTECTION AND TEMPORARY DISABLE

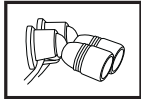

The volumetric protection system uses Echo/Doppler technology and orientable sensors to achieve high performance and excellent false alarm immunity. The sensitivity set in the factory adequately protects all vehicles thanks to an automatic system that adapts to the volume to be protected. It is possible to use the PRG007 PROGRAMMER if you want to vary this setting. To temporarily disable volumetric protection, use the remote control during the immunity time as described in the user manual.

SENSOR INSTALLATION

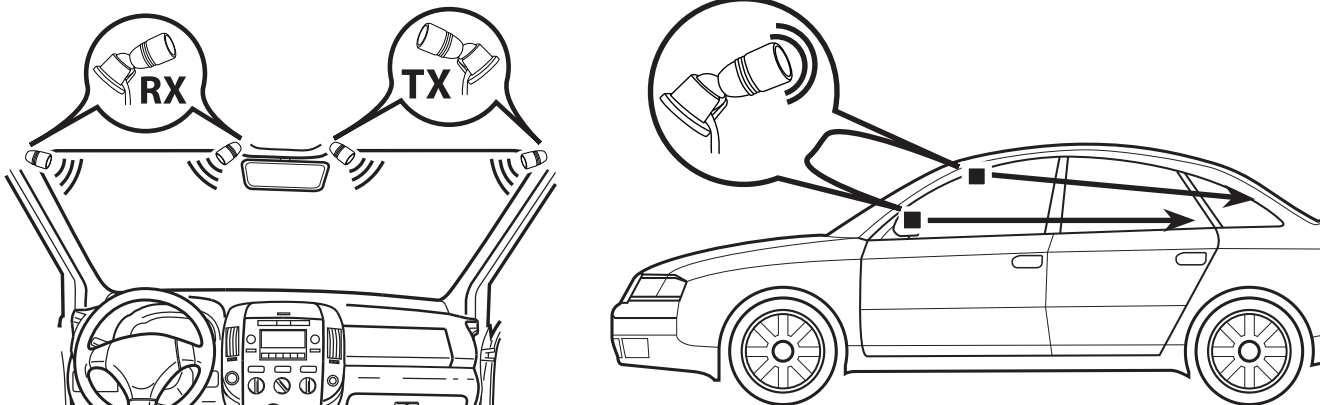
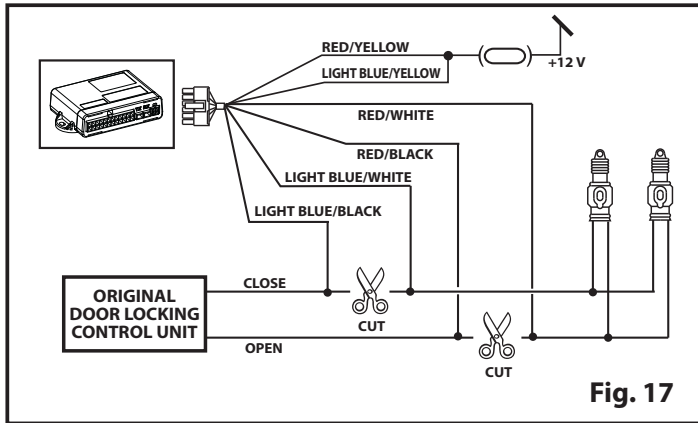

Fig. 16

CENTRAL LOCKING

DIRECT CONTROLS



ADDITIONAL ACTUATOR CONTROLS

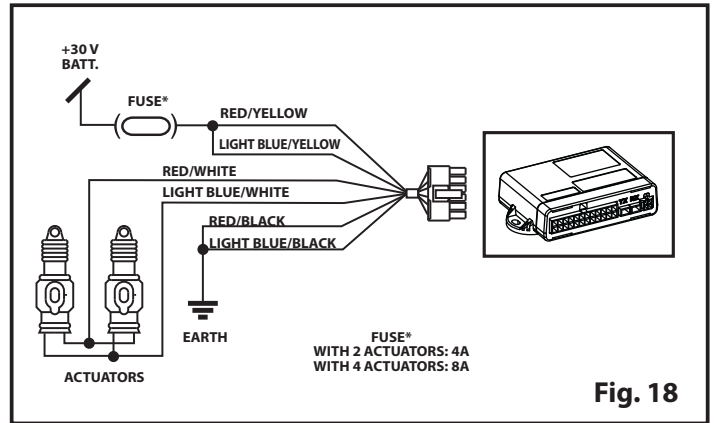

PNEUMATIC CLOSING CONTROLS

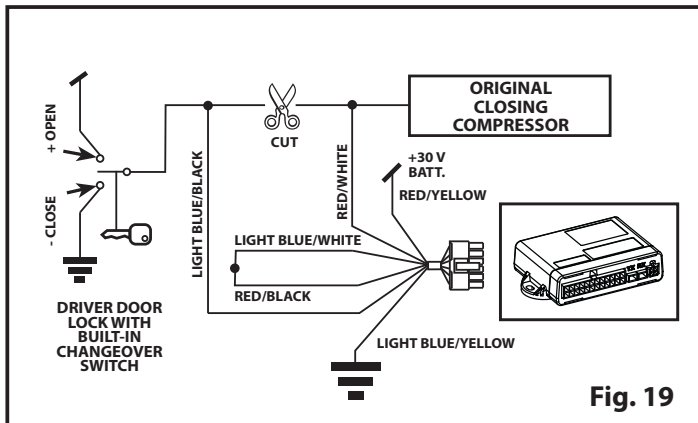
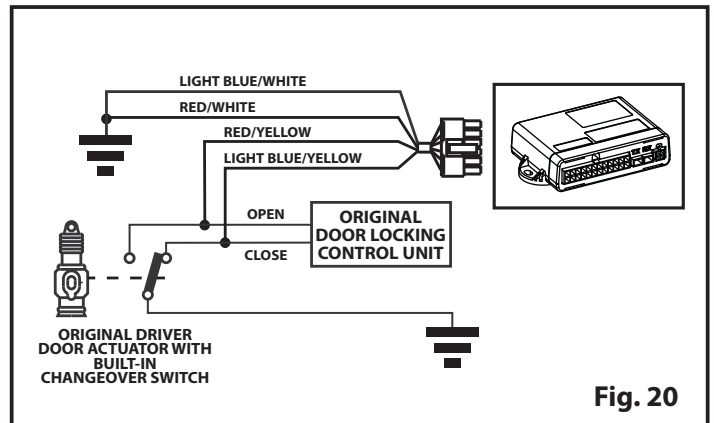

DIAGRAM FOR NEGATIVE CLOSING



BREAK TO CLOSE CONTROL

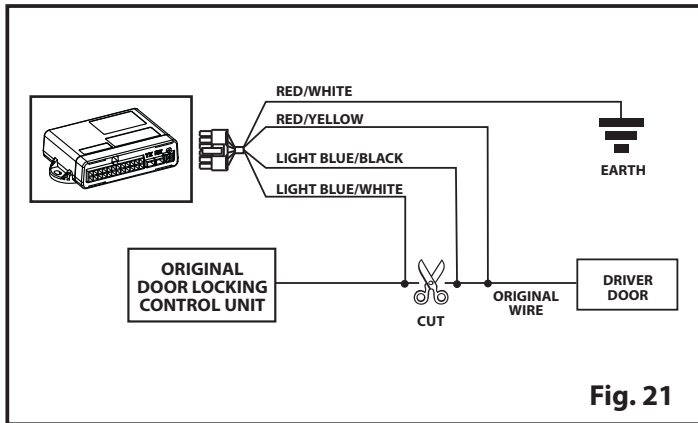
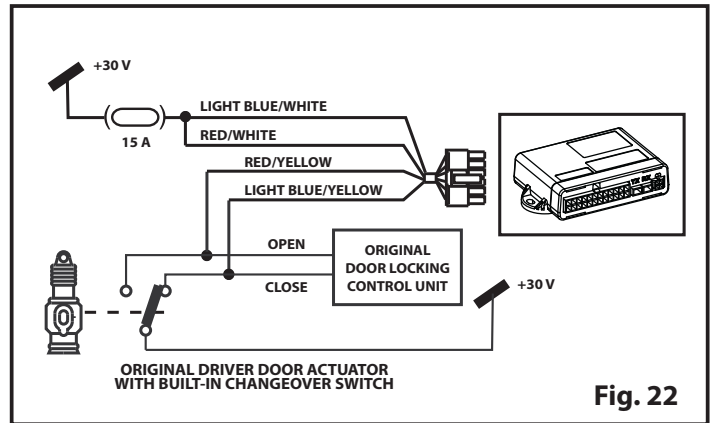
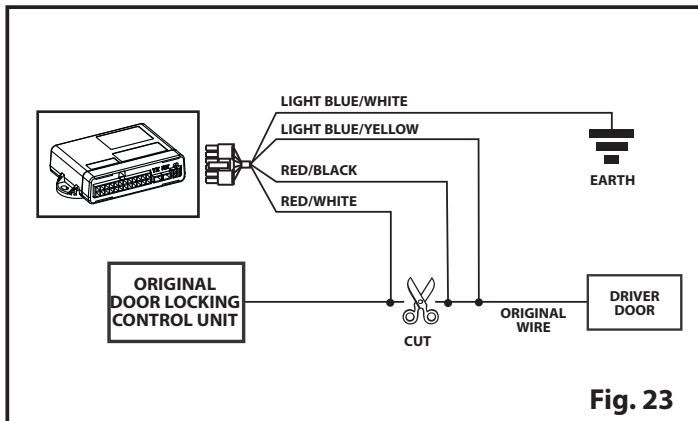

DIAGRAM FOR POSITIVE CLOSING



BREAK TO OPEN CONTROL



TILT PROTECTION/SHOCK SENSOR

The product has a sensor to detect attempts to lift the vehicle or shocks to it. Use the PRG007 PROGRAMMER to enable this sensor, and to obtain the best performance, ensure that the control unit is properly secured to a rigid part of the vehicle.

When using the shock sensor, it is possible use either the PRG007 PROGRAMMER or a manual procedure to adjust its sensitivity once the control unit has been installed and secured to the vehicle.

MANUALLY ADJUSTING THE SHOCK SENSOR (IF ALREADY ENABLED WITH THE PRG007):

- With the anti-theft system disabled, simultaneously press the button/LED and key A on the radio remote control; the LED will turn on continuously to indicate that the adjustment can be made.
- Each time you press key A, the sensitivity is incremented by one step, until it reaches the maximum value; each time you press key B, the sensitivity decreases, until it reaches the minimum.
- You can check the sensitivity during adjustment as the product emits an acoustic signal and flashes the direction indicators every time it detects a shock.
- The product returns to normal operation mode when the instrument panel is activated or one minute after the last operation performed (adjustment or test).

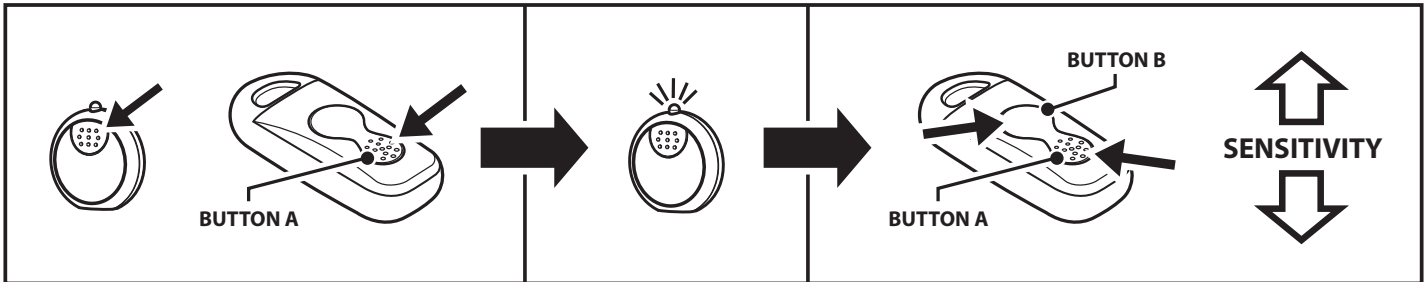

ENABLING AND PAIRING THE SIREN, RADIO REMOTE CONTROLS AND ELECTRONIC KEYS

Once you have made the electrical connections to the alarm, connect the vehicle battery, check that the vehicle instrument panel is off and power up the Meta HPA Evo control unit. As it is new, it will automatically store its components.

PAIRING THE SIREN: a few seconds after powering up the control unit, it will store the siren that is connected, and will emit a Boop to confirm. Wait for the LED to start flashing quickly and then continue with storing the radio remote controls.

PAIRING THE RADIO REMOTE CONTROLS: simultaneously press the 2 keys on the first radio remote control; the LED will turn off for 2 seconds to confirm. Repeat the operation for all of the other radio remote controls to be paired, each time checking that they have been stored successfully.

PAIRING THE ELECTRONIC KEYS: after pairing the radio remote controls, continue with storing the electronic keys by inserting them in the receptacle one after the other, each time checking that they have been stored successfully.



To complete the storing phase, wait for 1 minute, or activate the instrument panel; if you need to add other components once storage has been completed, you must use the PRG007 programmer to activate the pairing phase again.

LED/ELECTRONIC KEYS

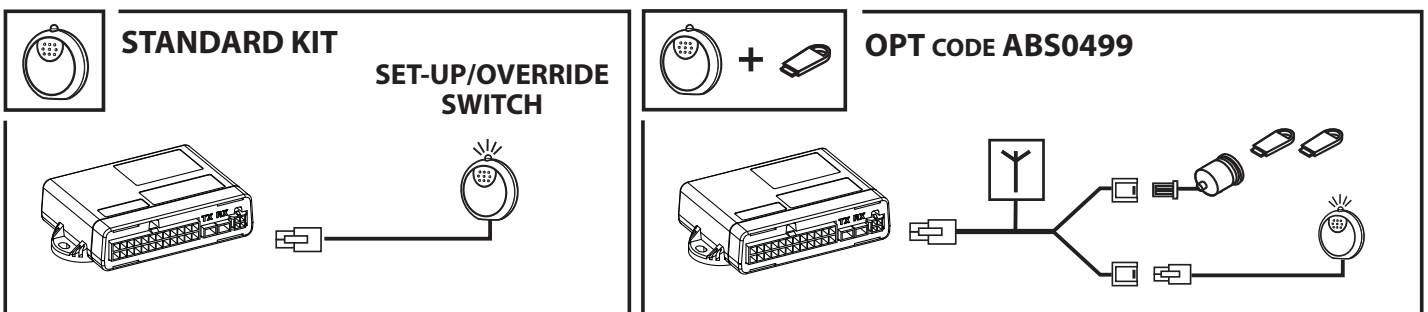

MANUAL PROGRAMMING OF ADDITIONAL KEYS

It is necessary to have an operational touch key to enable this process:

Insert touch key into receptacle, hold for 5 seconds, until the LED flashes rapidly.

New Touch key: Insert into the receptacle.

New Radio Key: Press both buttons, simultaneously, of the new radio key.

The programming window closes after 60 seconds, or on ignition ON.

USER INSTRUCTIONS

Dear customer,

Before reading the user instructions in the following pages, we wish to congratulate you for choosing a Meta System product, and we are pleased to give you some general information that will help you understand the performance of your new alarm system.

During your absence, the alarm monitors if anyone opens any compartment of the car, disconnects the power or forces entry into the passenger compartment by breaking a window. Using the radio remote control provided, you can enable or disable the anti-theft system, temporarily disable some of the protection devices or close the electric windows if the car is equipped with the Comfort system, or if an additional window closing module is installed.







MAIN FUNCTIONS

- The alarm is enabled as soon as you lock the car doors by pressing key A on the radio remote control provided. The direction indicators will flash twice and the LED will flash to signal that it has been enabled, and it will become fully operational after 25 sec. If you want to temporarily disable the ultrasonic volumetric protection or the tilt/shock sensor, just press key B on the radio remote control one or more times, as described in the "Disabling the Protection Devices" chapter.
- The alarm is disabled when you unlock the doors by pressing key A on the radio remote control provided. The direction indicators will flash once and the LED will be off to signal that it has been disabled.







If the radio remote control is not available, the anti-theft system will produce an visual/acoustic alarm when the door is opened. This can be turned off by entering the Override security code or by using an electronic key, as described in the "Emergency Override" chapter.

FUNCTIONS OF THE RADIO REMOTE CONTROL KEYS

The alarm control unit has a standard operating mode in which the radio remote control keys act as follows:

FUNCTION	ACTION	FEEDBACK	LED
Enable anti-theft system	KEY A Press once 	Indicators flash twice	Flashing: Off briefly for the first 26 sec. (initial immunity) then slow flashing
Disable anti-theft system	KEY A Press once 	Indicators flash once	Off if no alarms have occurred. Flashing sequence if there are alarms in the memory
Disable volumetric protection	KEY B Press once 	Indicators flash 3 times Siren beeps 3 times	Very fast flashing for the first 26 sec.
Disable auxiliary + tilt protection	KEY B Press twice 	Indicators flash 4 times Siren beeps 4 times	Very fast flashing for the first 26 sec.
Disable volumetric + auxiliary + tilt protection	KEY B Press 3 times 	Indicators flash 5 times Siren beeps 5 times	Very fast flashing for the first 26 sec.
Panic Alarm (if enabled); 10 sec. alarm cycle	KEY B Press once 	Indicators flash and siren sounds	Fast flashing during the alarm
Stop alarm cycle	KEY B Press once 	Indicators turn off and siren stops	Slow flashing

NB: you can ask your installer to change the functions of the radio remote control keys by choosing the CUSTOM SETTING modes. In this case, the radio remote control functions as follows:

FUNCTION	ACTION	FEEDBACK	LED
Enable anti-theft system	KEY A Press once 	Indicators flash twice	Flashing: Off briefly for the first 26 sec. (initial immunity) then slow flashing
Disable anti-theft system	KEY B Press once 	Indicators flash once	Off if no alarms have occurred. Flashing sequence if there are alarms in the memory
Disable volumetric protection	KEY A Press once 	Indicators flash 3 times Siren beeps 3 times	Very fast flashing for the first 26 sec.
Disable volumetric + auxiliary + tilt protection	KEY A Press twice 	Indicators flash 4 times Siren beeps 4 times	Very fast flashing for the first 26 sec.
Disable volumetric + auxiliary + tilt protection	KEY A Press 3 times 	Indicators flash 5 times Siren beeps 5 times	Very fast flashing for the first 26 sec.
Panic Alarm (if enabled); 10 sec. alarm cycle	KEY A Press once 	Indicators flash and siren sounds	Fast flashing during the alarm
Stop alarm cycle	KEY A Press once 	Indicators turn off and siren stops	Slow flashing

VEHICLE PROTECTION DEVICES

When it is enabled, the alarm monitors:

- opening of the doors, boot and bonnet;
- inside the passenger compartment using volumetric protection (available in the HPA US model).
- disconnection of the main power supply using the M05 siren, which has its own power supply battery.
- attempts to start the engine.
- vehicle lifting or shocks, depending on the protection mode selected during installation.

During the first 26 seconds after enabling the alarm, any break-in events will trigger the direction indicators to flash together with an acoustic signal; after 26 seconds, the system enters a pre-alarm state, and any trigger causes the system to generate an alarm.

DOOR OR BOOT OPEN WARNING WHEN ENABLING

A few seconds after enabling the alarm, the system will give 4 brief acoustic signals to warn you if a door, the bonnet or the boot are not closed properly.















VISUAL/ACOUSTIC ALARM

In the event of a break-in, the anti-theft system performs a 26 sec. alarm cycle, during which the siren will emit a modulated sound and the direction indicators will flash. To stop the alarm cycle, you can press key B on the radio remote control or disable the anti-theft system by pressing key A.

NB: if you chose CUSTOM SETTING for the radio remote control, you will need to press key A on the radio remote control to stop the alarm and B to disable it.

ALARM TRIGGERED WARNING AND ALARM MEMORY

If an alarm was triggered in your absence, the siren will emit a Boop when you disable the anti-theft system with the radio remote control to warn you that an alarm had occurred. You will be able to see the alarm type from the number of times the LED flashes and comparing it to the table below. The flashing LED and corresponding alarm memory will be cleared when you turn on the vehicle instrument panel, or the next time you enable the anti-theft system.

ALARM TYPE TRIGGERED		LED SIGNAL (flashing sequence)
Ultrasonic	 	1
Doors	 	2
Bonnet	 	3
Boot	 	4
Auxiliary modules (Positive alarm)	 	5
Instrument panel (+15)	 	6
Tilt/Shock Sensor	 	7

TEMPORARILY DISABLING THE ULTRASONIC PROTECTION

If you want to leave the vehicle with the windows open, you must disable the ultrasonic sensors to prevent false alarms. To disable volumetric protection, enable the alarm and press key B on the radio remote control within 20 sec. To confirm that the volumetric protection has been disabled for the whole time that the alarm is enabled, the LED will flash very fast for the first 20 sec., and the direction indicators will flash a few times with the corresponding acoustic signal.

NB: if you chose CUSTOM SETTING for the radio remote control, you will need to press key A on the radio remote control.

DISABLING OPTIONAL MODULES AND VEHICLE TILT/SHOCK PROTECTION







If you want to lock the car and enable the alarm while transporting it on another vehicle or on a ferry, you must disable any optional modules as well as the tilt and shock protection.

To disable volumetric protection, enable the alarm and press key B on the radio remote control within 20 sec. To confirm that the protection has been disabled for the whole time that the alarm is enabled, the LED will flash very fast for the first 20 sec., and the direction indicators will flash a few times with the corresponding acoustic signal.

Press the key 3 times to disable ultrasonic, optional, tilt and shock protection.

NB: if you chose CUSTOM SETTING for the radio remote control, you will need to press key A twice on the radio remote control.

MAIN LED SIGNALS

LED SIGNAL		CONTROL UNIT STATUS
Off	 _____	Control unit disabled or off
Slow flashing	 	Enabled and in surveillance mode
Fast flashing	 	In initial immunity mode
Very fast	 	In initial immunity mode with volumetric protection disabled

ADDITIONAL FUNCTIONS

You can ask your installer to enable some product functions that you can control using the keys on the radio remote control. Below there is a brief description; your installer will be able to give you a more detailed explanation:

PANIC FUNCTION: if this function is active and the anti-theft system is enabled, you can press key B on the radio remote control to trigger an alarm cycle.

COMFORT FUNCTION: if this function is active, you can postpone central locking to allow the windows to close.

EMERGENCY OVERRIDE

There are two different emergency override systems; the first consists of entering the secret unlocking code using the button/LED, and the second is the optional electronic key system. If you have the electronic key, just insert it into the special receptacle to disable the anti-theft system, while to use the button/LED, you must follow the instructions given below:

1. Activate the instrument panel and immediately deactivate it; the LED will turn on continuously, turn off and then start to flash after 2 seconds.
2. Count the number of flashes, and once that number corresponds to the first digit of the Override code, press the button to confirm it; 3 quick flashes will follow to confirm that the selected digit has been entered, and the LED will start to flash again after 2 seconds, allowing you to enter the next digit.
3. Repeat step 2 for all of the digits in the Override code. When you have finished, the anti-theft system will be disabled if you have entered the correct code.

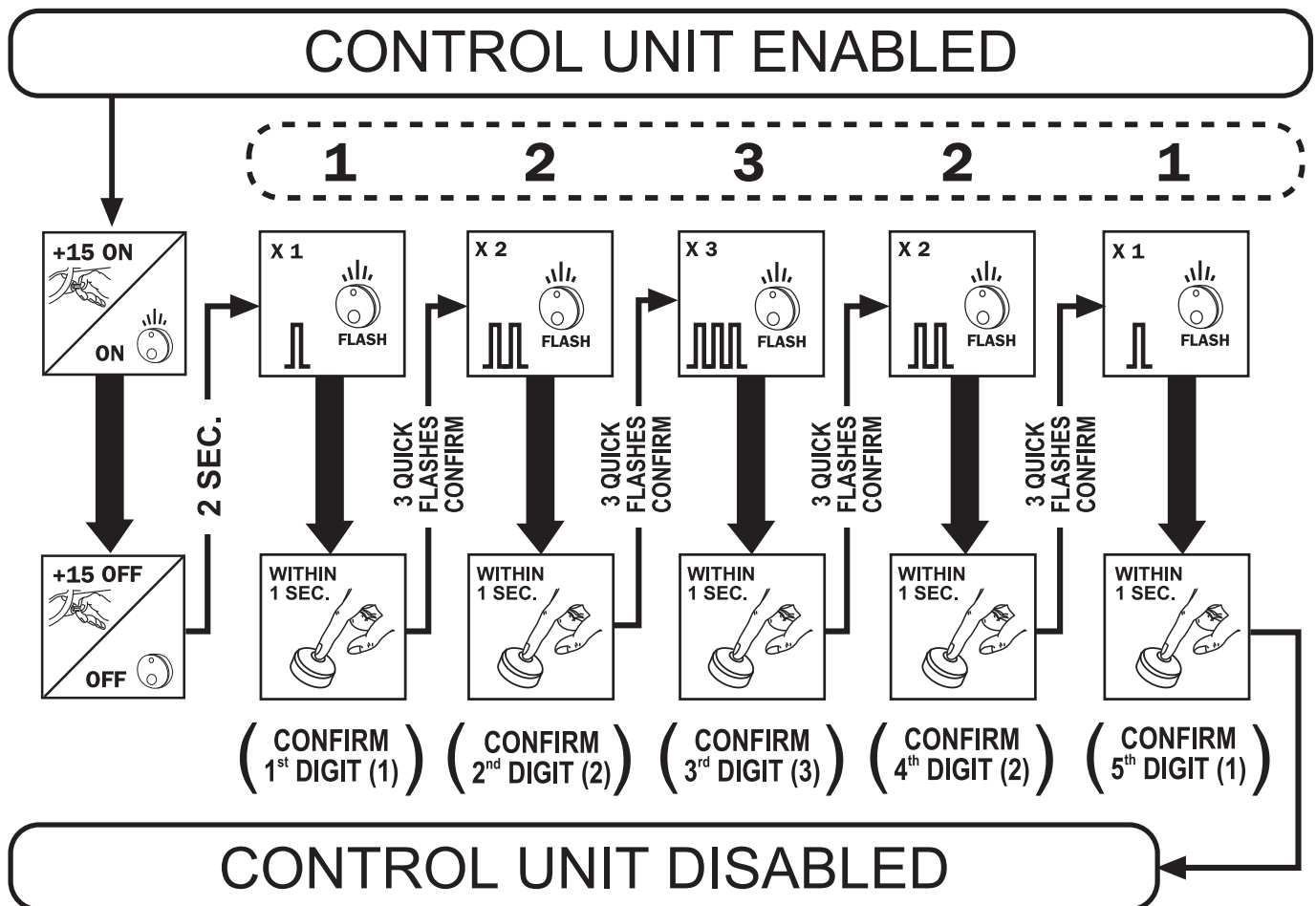

NB: While entering the Override code, it is likely that the alarm will sound because it detects an attempt to break in or start the engine; moreover, if no digit is confirmed during the flashing sequence, or if an incorrect Override code is entered, the anti-theft system will remain enabled. You are allowed up to three attempts to enter the Override code. If all three attempts are incorrect, you will have to wait at least 10 minutes before trying again.